

Intrinsically Safe Outdoor Call Points

IS-WCP 1 Resistor & Clean Contact Model (Red Versions)



> Product Benefits

- Sealed to IP67
- Unique 'Plug & Play' installation concept
- Total 'Flex-Ability' in the choice of operating element
- Anti-Tamper facility
- Enhanced aesthetics and compact design
- Fully approved to the latest standards
- CPD Approval



II 1GD Ex ia IIC T4 Ga
Sira 06ATEX2131X
IECEX SIR 08.0105X

Product Overview

An Intrinsically Safe version of our WCP1A outdoor call point is available for installation in hazardous areas. These call points are manufactured to protect against other hazards, as defined in paragraph 1.2.7 of annex II of the ATEX Directive 94/9/EC. They are intended for outdoor use within Intrinsically Safe (I.S.) systems using suitable I.S. barriers (contact KAC for a list of approved barriers).

Installation efficiency, flexibility and full compliance with the latest standards are at the heart of the new WCP outdoor Call Point range.

The outdoor WCP is an IP67 sealed manual call point product. The enhanced environmental protection allows the unit to be installed in many external environments where water and dirt are likely to be present, making it a true waterproof and outdoor product.

Installation time and ultimately cost, are of paramount importance to any fire or security installer. The WCP range directly reflects this need by providing a unique 'plug and play' concept designed specifically to reduce installation time. All new WCP products utilise a special terminal block, where all initial installation cabling is terminated. This terminal block is then simply connected to the back of the WCP. Simple, but effective with no re-termination required and no time wasted. In addition, all WCP products are supplied with three standard 20mm threaded holes for cable entries, accommodating all types of surface wiring installations.

Through new standards and legislation, both break glass and re-settable operating elements can now be used within a manual call point. To provide you with the greatest 'flex-ability', the new WCP range can be configured as either a break glass or re-settable unit by simply changing from one element to another. No other additional parts or alternative products need to be ordered.

All WCP Outdoor Call Point products also help preserve the integrity of the overall system as illegal removal of the product lid will result in the call point operating and the system going in to alarm.

Full compliance with the latest standards is essential and the new WCP indoor call point range is fully approved to the latest EN54-11 standard.

The WCP1A product version is supplied with both a resistor and normally open clean contact electrical options. These options are easily utilised by simply connecting the terminal block to the required connection in the back of the WCP1 product. A variety of resistor versions are available, with both 470Ω and 680Ω offered as standard. However, other resistor types can be provided upon request.

The WCP1B version allows connection to "Savwire" systems.



KAC

ISWCP1
Rev. No. 2

Electrical Specification

Connection Details: See Figure .1
Cable Termination: 0.5-2.5mm²
Maximum Voltage: 30VDC
Switch Rating: 2 Amps
Certification Details: II 1GD Ex ia IIC T4 Ga (-30°C ≤ T_a ≤ +70°C)
 Ex iaD T135°C Da (-20°C ≤ T_a ≤ +40°C) when P_i = 0.75W
 (-20°C ≤ T_a ≤ +70°C) when P_i = 0.65W
 Sira 06ATEX2131X
 IECEx SIR 08.0105X

Figure .1

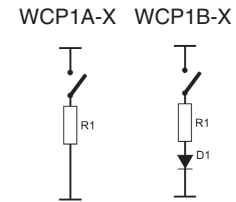

Suitable IS Barriers:

**Pepperl & Fuchs -
MTL -**

KFDO-Cs-Ex 1.51P (BAS98ATEX7343), KFDO-Cs-Ex 2.51P (BAS98ATEX7343)
 MTL4061 (BAS01ATEX7176), MTL5061 (BAS01ATEX7160)

A certified shunt zener barrier may be used having the following output parameters;

U_z - 28V, I_{max} - 93.3mA, W_{max} - 0.67W

Environmental Specification

Humidity: 0-93±3% non-condensing
Operating Temperature: -25°C to +70°C
Storage Temperature: -25°C to +70°C
Ingress Protection (IP) Rating: IP67
 For RoHS, WEEE & REACH data please see www.kac.co.uk

Mechanical Specification

Material: PC/ABS
Weight: 350g
Colour: Red, Ral 3001

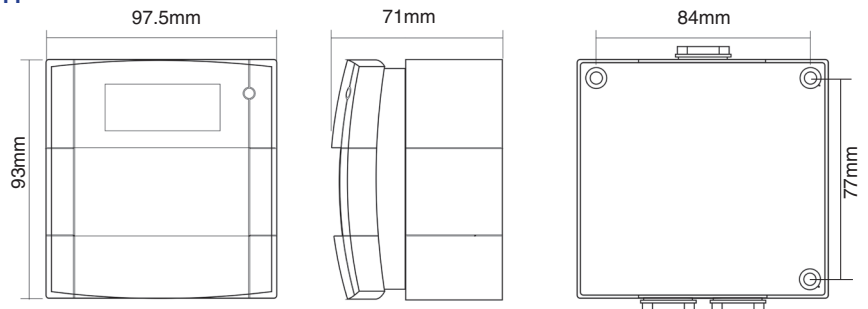

Ordering Information

Model	Electrical Configuration	Mounting	Operating Element	Markings
WCP1A-R470SG-K013-01IS	470Ω Resistor & N/O 30VDC	Surface	Glass	EN54-11
WCP1A-R470SF-K013-01IS	470Ω Resistor & N/O 30VDC	Surface	Flexi	EN54-11
WCP1B-R470SG-K013-01IS	470Ω Resistor & N/O 30VDC (SAV)	Surface	Glass	EN54-11
WCP1B-R470SF-K013-01IS	470Ω Resistor & N/O 30VDC (SAV)	Surface	Flexi	EN54-11

Also available with 680Ω Resistor
 N/O = Normally Open Contact
 SAV = Sawwire system

Accessories

Code	Description
SC070	Pack Of Ten Test Keys
KG1 x 5	Pack Of Five Glass Elements (Also available in packs of 10, 25 & 50)
PS210	Flexible Operating Element
PS200	Plain Hinged Cover
SC071	Pack Of Twenty Terminal Blocks

> KAC Alarm Company Ltd

KAC House, Thornhill Road,
 North Moons Moat, Redditch,
 B98 9ND, United Kingdom
 Tel: +44 (0) 1527 406655
 Fax: +44 (0) 1527 406677
 e-mail: marketing@kac.co.uk

KAC