

WCP Outdoor Call Point Range

WCP1 Resistor & Clean Contact Model (Colour Versions)



> Product Benefits

- Sealed to IP67
- Unique 'Plug & Play' installation concept
- Total 'Flex-Ability' in the choice of operating element
- Anti-Tamper facility
- Enhanced aesthetics and compact design



Product Overview

Installation efficiency, flexibility and full compliance with the latest standards are at the heart of the new WCP Outdoor Call Point range.

The outdoor WCP is an IP67 sealed manual call point product. The enhanced environmental protection allows the unit to be installed in many external environments where water and dirt are likely to be present, making it a true waterproof and outdoor product.

Installation time and ultimately cost, are of paramount importance to any fire or security installer. The WCP range directly reflects this need by providing a unique 'plug and play' concept designed specifically to reduce installation time. All new WCP products utilise a special terminal block, where all initial installation cabling is terminated. This terminal block is then simply connected to the back of the WCP. Simple, but effective with no re-termination required and no time wasted. In addition, all WCP products are supplied with three standard 20mm threaded entries, accommodating all types of surface wiring installations.

Both break glass and re-settable operating elements can now be used within a manual call point. To provide you with the greatest 'flex-ability', the new WCP range can be configured as either a break glass or re-settable unit by simply changing from one element to another. No other additional parts or alternative products need to be ordered.

All WCP Outdoor Call Point products also help preserve the integrity of the overall system as illegal removal of the product lid will result in the call point operating and the system going in to alarm.

The WCP1A product version is supplied with both a resistor and normally open clean contact electrical options. These options are easily utilised by simply connecting the terminal block to the required connection in the back of the WCP1 product. A variety of resistor versions are available, with both 470Ω and 680Ω offered as standard. However, other resistor types can be provided upon request. The WCP1B product version allows for connection to "sawwire" systems.

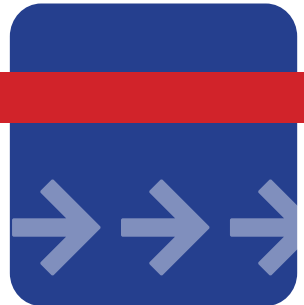

KAC

WCP1-COL
Rev. No.2

Electrical Specification

Connection Details: See Figure .1
 Cable Termination: 0.5-2.5mm²
 Maximum Voltage: 30VDC
 Switch Rating: 2 Amps

Figure .1
WCP1A-X



Environmental Specification

Humidity: 0-93±3% non-condensing
 Operating Temperature: -25°C to +70°C
 Storage Temperature: -25°C to +70°C
 Ingress Protection (IP) Rating: IP67
 For RoHS, WEEE & REACH data please see www.kac.co.uk

Mechanical Specification

Material: PC/ABS
 Weight: 350g
 Colours: Green,
 White,
 Yellow,
 Blue,
 Orange.

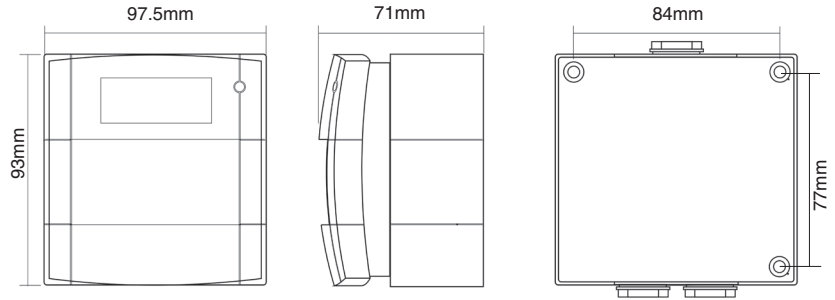

Ordering Information

Model	Electrical Configuration	Colour	Mounting	Operating Element	Markings
WCP1A-G470SG-K013-11	470Ω Resistor & N/O 30VDC	Green	Surface	Glass	Plain
WCP1A-G470SG-K013-12	470Ω Resistor & N/O 30VDC	Green	Surface	Glass	EDR
WCP1A-G470SF-K013-11	470Ω Resistor & N/O 30VDC	Green	Surface	Flexi	Plain
WCP1A-G470SF-12	470Ω Resistor & N/O 30VDC	Green	Surface	Flexi	EDR
WCP1B-G470SG-K013-11	470Ω Resistor & N/O 30VDC	Green	Surface	Glass	Plain
WCP1B-G470SG-K013-12	470Ω Resistor & N/O 30VDC	Green	Surface	Glass	EDR
WCP1B-G470SF-K013-11	470Ω Resistor & N/O 30VDC	Green	Surface	Flexi	Plain
WCP1B-G470SF-K013-12	470Ω Resistor & N/O 30VDC	Green	Surface	Flexi	EDR

N/O = Normally Open Contact
 Also available with 680Ω Resistor
 WCP variants are available in Blue, Yellow or White if appropriate.

Accessories

Code	Description
SC070	Pack Of Ten Test Keys
KG1 x 5	Pack Of Five Glass Elements (<i>Also available in packs of 10, 25 & 50</i>)
PS210	Flexible Operating Element
PS200	Plain Hinged Cover
SC071	Pack Of Twenty Terminal Blocks

> KAC Alarm Company Ltd

KAC House, Thornhill Road,
 North Moons Moat, Redditch,
 B98 9ND, United Kingdom
 Tel: +44 (0) 1527 406655
 Fax: +44 (0) 1527 406677
 e-mail: marketing@kac.co.uk